

NSTT
GmbH



Drehbohrgerät **GEAX DTC50**

 **GEAX**
Vertragshändler

NEUF
Spezialtiefbautechnik

- Beratung
- Vermietung
- Verkauf
- Service

DTC50

HYDRAULIC PILING RIG

 **GEAX**



GEAX DTC50

AGILITY ON SITE

COMPACT DESIGN

The DTC50, like all the Geax DTC series rigs is characterized by a very compact design which makes it the machine of choice for limited access, narrow and very low headroom jobsites.

UNIQUE ARCHITECTURE

The Geax DTC series are characterised by a long supporting boom and a sliding monolithic mast which encloses the kelly bar internally. This solution guarantees a stiffer and lighter design, enabling a great variety of tool positioning including long reach.

S version

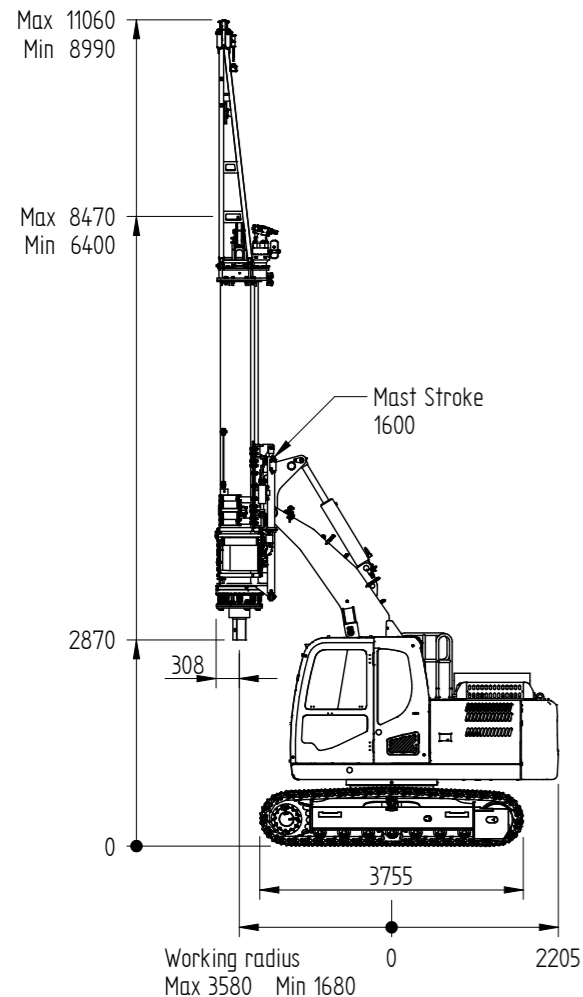

MANEUVERABILITY

With its compact dimensions and proverbial stability, the DTC50 can drill in any site including slopes, uneven terrains, and tight spaces. The higher maneuverability allows fast movements compared to a traditional rig.

HIGH PRODUCTIVITY

Thanks to the high maneuverability on site, and the efficiently engineered hydraulics with high quality components, the DTC50 offers superior performance relative to the size, while keeping very low running costs.

L version

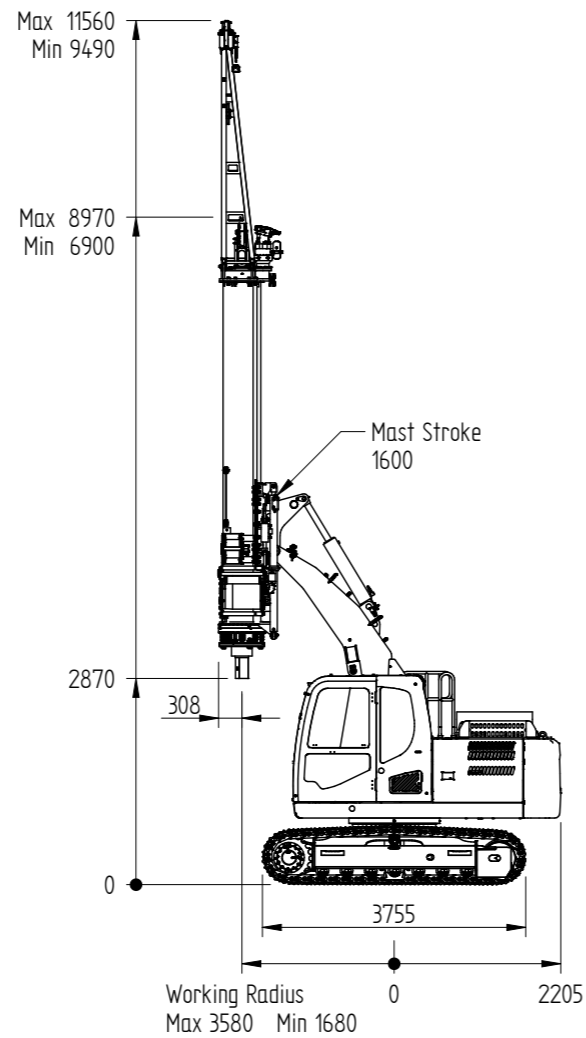

TECHNICAL DATA SHEET

BASE CARRIER

Engine	type	G2 D34 - DL06
Exhaust emission	EU EPA	Stage V - III Tier4f - 3
Engine power	kW (hp)	86 (115) - 71 (95)
Main pumps	l/min	2x114
Hydraulic pressure	bar	330

MAST

Forward tilt	deg	>10
Backward tilt	deg	>10
Lateral tilt	deg	± 6.5
Mast vertical stroke	mm - ft	1.600 - 5.25

WINCHES

Main winch line pull (1st layer)	kN - lbf	82 - 18.440
Aux winch line pull (1st layer)	kN - lbf	36 - 8.100

DRILLING

		S version	L version
Max pile diameter ¹	mm - in	1.200 - 48	1.200 - 48
Std pile depth	m - ft	21 - 69	25 - 82
Max pile depth	m - ft	21 - 69	25 - 82
Rotary stroke on mast	mm - ft	-	-
Total rotary stroke	mm - ft	1.600 - 5.25	1.600 - 5.25
Min working headroom	mm - ft	6.400 - 21	6.900 - 22.6

TRANSPORT

		S version	L version
Length	mm - ft	8.000 - 26.2	8.500 - 27.9
Width	mm - ft	2.540 - 8.3	2.540 - 8.3
Height	mm - ft	2.900 - 9.5	2.900 - 9.5
Weight	kg - lbs	18.000 - 39.680	18.900 - 41.670

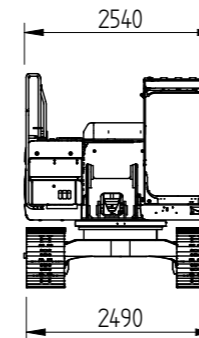

UNDERCARRIAGE

Tracks width	mm - ft	2.490 - 8.2
Tracks length	mm - ft	3.755 - 12.3
Track shoes	mm - ft	500 - 1.64
Tail radius	mm - ft	2.205 - 7.23

ROTARY HEAD

Torque (nominal)	kNm - lbf ft	46 - 34.000
Drilling speed	rpm	10 - 65
Spin-off speed	rpm	65

CROWD SYSTEM

Pull down force	kN - lbf	110 - 24.750
Extraction force	kN - lbf	125 - 28.100

KELLY BAR OPTIONS

n° elements x m		Depth
6 x 4 (standard S)	m - ft	21 - 68.9
6 x 4.6 (standard L)	m - ft	25 - 82
5 x 4 Heavy Duty S	m - ft	18 - 59
5 x 4.6 Heavy Duty L	m - ft	22 - 72.2

All kelly bars are round interlocking

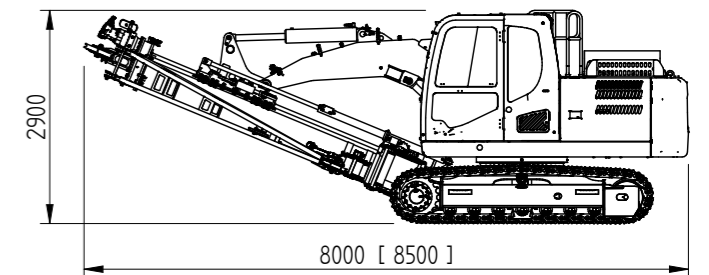

- Values are effective except where otherwise specified.
- Technical data are provided as indicative information only, they are subject to change without prior notice.

NOTES: 1. Recommended



WWW.GEAX.IT
email: info@geax.it
tel: +39 0717131953

GEAX srl
Contrada Passatempo 19
Montefano (MC) ITALY



Zubehör

Für alle angebotenen Maschinen können Sie über die NSTT GmbH selbstverständlich auch passendes Zubehör kaufen oder anmieten. Wir liefern schnell und unkompliziert die benötigten Zubehöerteile.

Gebrauchartikel sind in überprüfem und einwandfreiem Zustand.

- Kellystangen
- Drehteller
- Bohrrohre (div. Durchmesser)
- Kastenbohrer
- Schneckenbohrer
- Abfangschellen
- Betonierschüttrohre
- u.v.m.



NEUF
Spezialtiefbautechnik



Ihr Ansprechpartner:
Hubert Neuf
Geschäftsführer

NSTT GMBH
NEUF SPEZIALTIEFBAUTECHNIK
Industriering 12
63868 Großwallstadt

Tel.: +49 60 22- 70 91 92 - 0
Fax: +49 60 22- 70 91 92 - 20
Mail: info@nstt.de

www.nstt.de

Konstruktionsentwicklungen und Prozessverbesserungen können Aktualisierungen und Änderungen von Spezifikationen und Materialien ohne vorherige Ankündigung oder Haftung erforderlich machen. Die Abbildungen enthalten möglicherweise optionale Ausstattung und zeigen nicht alle möglichen Konfigurationen. Diese Angaben und die technischen Daten haben ausschließlich Informationscharakter. Irrtum und Druckfehler vorbehalten.